



### Main

Range of product	TeSys F
Range	TeSys
Product name	TeSys F
Product or component type	Contactor
Device short name	LC1F
Contactor application	Motor control Resistive load
Motor power kW	75 kW at 400 V AC 50/60 Hz AC-4 200 kW at 380...400 V AC 50/60 Hz AC-3 220 kW at 415 V AC 50/60 Hz AC-3 250 kW at 440 V AC 50/60 Hz AC-3 257 kW at 500 V AC 50/60 Hz AC-3 280 kW at 660...690 V AC 50/60 Hz AC-3 185 kW at 1000 V AC 50/60 Hz AC-3 110 kW at 220...230 V AC 50/60 Hz AC-3
Control circuit type	AC 40...400 Hz
[Uc] control circuit voltage	110 V AC 40...400 Hz
[Uimp] rated impulse withstand voltage	8 kV
Overvoltage category	III
[Ith] conventional free air thermal current	500 A at $\leq 40$ °C
Rated breaking capacity	3200 A conforming to IEC 60947-4-1
[Icw] rated short-time withstand current	3600 A $\leq 40$ °C 10 s 2400 A $\leq 40$ °C 30 s 1700 A $\leq 40$ °C 1 min 1200 A $\leq 40$ °C 3 min 1000 A $\leq 40$ °C 10 min
Associated fuse rating	400 A aM at $\leq 440$ V 500 A gG at $\leq 440$ V
Average impedance	0.26 mOhm at 50 Hz - Ith 500 A
[Ui] rated insulation voltage	1000 V conforming to IEC 60947-4-1 1500 V conforming to VDE 0110 group C

Disclaimer: This documentation is not intended as a substitute for and is not to be used for determining suitability or reliability of these products for specific user applications

Power dissipation per pole	42 W AC-3 65 W AC-1
Mounting support	Plate
Standards	EN 60947-1 EN 60947-4-1 IEC 60947-1 IEC 60947-4-1 JIS C8201-4-1
Product certifications	LROS (Lloyds register of shipping) ABS RINA RMRoS UL BV CB CSA DNV
Connections - terminals	Control circuit : screw clamp terminals 2 cable(s) 1...2.5 mm <sup>2</sup> - cable stiffness: flexible - with cable end Control circuit : screw clamp terminals 1 cable(s) 1...4 mm <sup>2</sup> - cable stiffness: flexible - without cable end Control circuit : screw clamp terminals 2 cable(s) 1...4 mm <sup>2</sup> - cable stiffness: flexible - without cable end Control circuit : screw clamp terminals 1 cable(s) 1...4 mm <sup>2</sup> - cable stiffness: flexible - with cable end Control circuit : screw clamp terminals 1 cable(s) 1...4 mm <sup>2</sup> - cable stiffness: solid - without cable end Control circuit : screw clamp terminals 2 cable(s) 1...4 mm <sup>2</sup> - cable stiffness: solid - without cable end Power circuit : lugs-ring terminals 2 cable(s) 150 mm <sup>2</sup> Power circuit : bar 2 x ( 30 x 5 mm) Power circuit : bolted connection
Tightening torque	Power circuit : 35 N.m Control circuit : 1.2 N.m
Operating time	100...170 ms opening 40...65 ms closing
Mechanical durability	10 Mcycles
Operating rate	2400 cyc/h at <= 55 °C

## Complementary

Utilisation category	AC-1 AC-3 AC-4
Poles description	3P
Pole contact composition	3 NO
[Ue] rated operational voltage	<= 1000 V AC 50/60 Hz <= 460 V DC
[Ie] rated operational current	500 A (<= 40 °C) at <= 440 V AC AC-1 400 A (<= 55 °C) at <= 440 V AC AC-3
Control circuit voltage limits	0.85...1.1 Uc at 55 °C operational 40...400 Hz 0.3...0.5 Uc at 55 °C drop-out 40...400 Hz
Inrush power in VA	1075 VA at 20 °C (cos φ 0.9) 40...400 Hz
Hold-in power consumption in VA	15 VA at 20 °C (cos φ 0.9) 40...400 Hz
Heat dissipation	14 W
Power range	110...220 kW 380...440 V 3 phases 110...220 kW 480...500 V 3 phases 110...220 kW 200...240 V 3 phases 250...500 kW 480...500 V 3 phases
Motor starter type	Direct on-line contactor
Contacting coil voltage	110 V AC standard

## Environment

IP degree of protection	IP20 front face with shrouds (ordered separately) conforming to IEC 60529 IP20 front face with shrouds (ordered separately) conforming to VDE 0106
Protective treatment	TH
Ambient air temperature for operation	-5...55 °C

Ambient air temperature for storage	-60...80 °C
Permissible ambient air temperature around the device	-40...70 °C
Operating altitude	3000 m without derating in temperature
Mechanical robustness	Vibrations contactor closed 5 Gn, 5...300 Hz Vibrations contactor open 1.5 Gn, 5...300 Hz Shocks contactor closed 15 Gn for 11 ms Shocks contactor open 6 Gn for 11 ms
Height	206 mm
Width	213 mm
Depth	219 mm
Product weight	9.1 kg

### Offer Sustainability

Sustainable offer status	Green Premium product
RoHS (date code: YYWW)	Compliant - since 0843 - Schneider Electric declaration of conformity <a href="#">Schneider Electric declaration of conformity</a>
REACH	Reference not containing SVHC above the threshold <a href="#">Reference not containing SVHC above the threshold</a>
Product environmental profile	Available <a href="#">Product environmental</a>
Product end of life instructions	Available <a href="#">End of life manual</a>

### Contractual warranty

Warranty period	18 months
-----------------	-----------

Dimensions and Drawings

LC1 F400 and F500

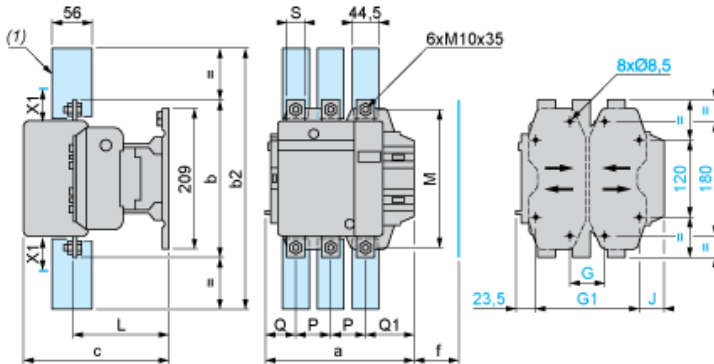

(1) Power terminal protection shroud

NOTE: X1 (mm) = Minimum electrical clearance according to operating voltage and breaking capacity.

LC1	200...500 V	600...1000 V
F400	15	20
F500	15	20

LC1		a	b	b2	c	f	G suppl	G min.	G max	G1 sup	G1 mir	G1 ma	J	L	M	P	Q	Q1	S
F400	2P	213	206	375	219	146	80	66	102	170	156	192	19.5	145	181	48	69	96	25
	3P	213	206	375	219	146	80	66	102	170	156	192	19.5	145	181	48	43	74	25
	4P	261	206	375	219	146	80	66	150	170	156	240	67.5	145	181	48	43	74	25
F500	2P	233	238	400	232	150	80	66	120	170	156	210	39.5	146	208	55	76	102	30
	3P	233	238	400	232	150	80	66	120	170	156	210	39.5	146	208	55	46	77	30
	4P	288	238	400	232	150	140	66	175	230	156	265	34.5	146	208	55	46	77	30

TeSys F reversing contactors and changeover contactor pairs Vertically mounted

NOTE: For customer assembly, with mechanical interlock (MI) LA9 F, fixing recommended on AM1 EC uprights (please consult your Regional Sales Office). 2 x LC1 identical or different ratings (LC1 F115 to F630 and F800).

Assembly A

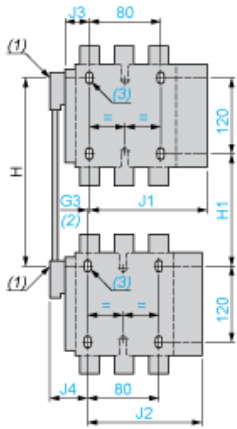

- (1) Mechanical interlock shaft.
- (2) For assembly of contactors of different ratings only.
- (3) 4 x Ø6.5 for LC1 F115 to F225.

Assembly A<sup>(7)</sup> - Mechanical interlock reference

	G3 3P	G3 4P	H min.	H max.	H1 min.	H1 max.	J1 3P	J1 4P
LA9 FF4F	0	0	200	310	80	190	137	155.5
LA9 FG4F	3	4	210	300	90	180	139.5	159.5
LA9 FG4G	0	0	220	310	100	190	139.5	159.5

	J2 3P	J2 4P	J3 3P	J3 4P	J4 3P	J4 4P
LA9 FF4F	137	155.5	48.5	67	48.5	67
LA9 FG4F	137	155.5	53	73	54	69
LA9 FG4G	139.5	159.5	53	73	53	73

Assembly B

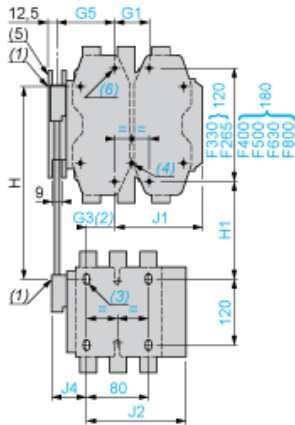

- (4) 4 x Ø6.5 for LC1 F265.
- (5) Mechanical interlock guide bracket.

Assembly B<sup>(7)</sup> - Mechanical interlock reference

	G1 3P	G1 4P	G3 3P	G3 4P	G5 3P	G5 4P	H min.	H max.
LA9 FH4F	96	96	21	27	60	83	240	380
LA9 FJ4F	80	80	45	26	83	83	250	380
LA9 FK4F	80	140	45	26	83	83	270	380
LA9 FL4F	180	240	35	17	74	74	310	380
LA9 FH4G	96	96	19	23	60	83	250	380
LA9 FJ4G	80	80	42	22	83	83	250	380
LA9 FK4G	80	140	42	22	83	83	270	380
LA9 FL4G	180	240	33	13	74	74	310	380

	H1 min.	H1 max.	J1 3P	J1 4P	J2 3P	J2 4P	J4 3P	J4 4P
LA9 FH4F	110	250	157.5	181.5	137	155.5	48.5	67
LA9 FJ4F	80	210	144.5	192.5	137	155.5	48.5	67
LA9 FK4F	100	210	164.5	219.5	137	155.5	48.5	67
LA9 FL4F	140	210	248.5	328.5	137	155.5	48.5	67
LA9 FH4G	120	250	157.5	181.5	139.5	159.5	53	73
LA9 FJ4G	90	220	144.5	192.5	139.5	159.5	53	73
LA9 FK4G	110	220	164.5	219.5	139.5	159.5	53	73
LA9 FL4G	150	220	248.5	328.5	139.5	159.5	53	73

Assembly C

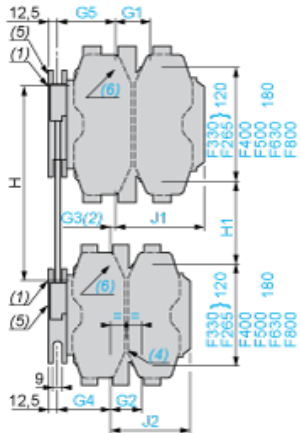

(6) 4 x Ø8.5 for LC1 F400, F500 or 4 x Ø10.5 for LC1 F630 and F800.

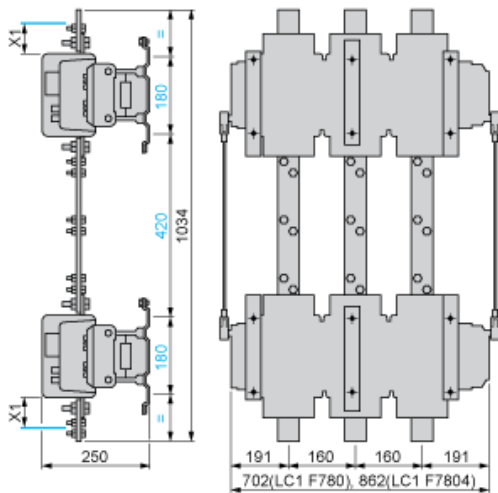

(7) Only 3P for F800.

(8) In this case, G4 is greater than G5.

Assembly C<sup>(7)</sup>

	G1 3P	G1 4P	G2 3P	G2 4P	G3 3P	G3 4P	G4 3P	G4 4P	G5 3P	G5 4P
LA9 FH4H	96	96	96	96	0	0	60	83	60	83
LA9 FJ4H	80	80	96	96	23	0	60	83	83	83
LA9 FK4H	80	140	96	96	23	0	60	83	83	83
LA9 FL4H	180	240	96	96	14	g <sup>(8)</sup>	60	83	74	74
LA9 FJ4J	80	80	80	80	0	0	83	83	83	83
LA9 FK4J	80	140	80	80	0	0	83	83	83	83
LA9 FL4J	180	240	80	80	g <sup>(8)</sup>	g <sup>(8)</sup>	83	83	74	74

	G1 3P	G1 4P	G2 3P	G2 4P	G3 3P	G3 4P	G4 3P	G4 4P	G5 3P	G5 4P
LA9 FK4K	80	140	80	140	0	0	83	83	83	83
LA9 FL4K	180	240	80	140	g <sup>(8)</sup>	g <sup>(8)</sup>	83	83	74	74
LA9 FL4L	180	240	180	240	0	0	74	74	74	74

	H min.	H max.	H1 min.	H1 max.	J1 3P	J1 4P	J2 3P	J2 4P
LA9 FH4H	250	380	130	260	157.5	181.5	157.5	181.5
LA9 FJ4H	260	380	110	230	144.5	192.5	157.5	181.5
LA9 FK4H	280	380	130	230	164.5	219.5	157.5	181.5
LA9 FL4H	330	380	170	220	248.5	328.5	157.5	181.5
LA9 FJ4J	260	380	60	200	144.5	192.5	144.5	192.5
LA9 FK4J	280	380	100	200	164.5	219.5	144.5	192.5
LA9 FL4J	325	380	140	195	248.5	329.5	144.5	192.5
LA9 FK4K	300	380	120	200	164.5	329.5	164.5	219.5
LA9 FL4K	345	380	160	195	248.5	328.5	164.5	219.5
LA9 FL4L	380	380	200	200	248.5	328.5	248.5	328.5

---

Connections and Schema

---

2, 3, and 4-pole Contactors

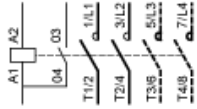

LC1 F115 to F630, F1250(coil LX1 F )

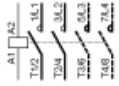





LC1 F115 to F630 , F1250 (coil LX4 F )

LC1 F115 to F265 (coil LX9 F )

LC1 F800 (coil LX8 F / )

Our Proposal - Type 1 : Thermal relay + Circuit Breaker + Contactor for Motor Power from 200 to 415 kW and 415 VAC

Motor power (kW)	ICU (kA)	Breaker	Thermal overload relay	Contactor (*)	Instantaneous auxiliary contacts
200 to 220	36	 LV432948	 LR9F7379	 LC1F400F7	 LADN22

Non contractual pictures.

Type 1 coordination requires that in a short-circuit condition, the contactor or starter must not present any danger to personnel or installations and must not be able to resume operation without repair or the replacement of parts.

(\*\*) You can select the breaker proposed or variants. Please consider examples hereafter or follow the link to the complete offer.

Motor power kW	ICU ( F )	Breaker with capacity level F	ICU ( H )	Breaker with capacity level H	ICU ( N )	Breaker with capacity level N	Other
200 to 220	36	LV432948	70	LV432950	50	LV432949	Complete Offer